

Innovations in touch-trigger probe sensor technology

Abstract

Since the invention of the touch-trigger probe in the 1970s, these devices have formed the main means of sensing for dimensional measurement on co-ordinate measuring machines (CMMs) and machine tools. Scanning sensors are increasingly being used on CMMs to measure complex shapes and to characterise the form of prismatic components. However, touch-trigger sensors still have a major role to play in the inspection of component size and position on CMMs, and in workpiece setup and in-process control on machine tools.

This module examines the performance characteristics of two key touch-trigger probe technologies (kinematic resistive and strain gauge) and highlights how development of these sensors continues to benefit manufacturers.

Kinematic resistive probes

The fundamental requirements for a touch-trigger probe are:

- **compliance** so that the stylus deflects when it meets the surface of the component, applies a low force to the component and allows time for the machine to decelerate before backing off the surface
- **mechanical repeatability** so that the stylus always returns to the same location relative to the machine quill / spindle when it is not in contact with the part
- **electrical repeatability** so that the probe always triggers at the same stylus deflection in any particular direction

The original touch-trigger probe is based on a spring-loaded kinematic arrangement of rods and balls, as shown in Figure 1. These provide six points of contact, ensuring that the stylus carrier is held in a unique location with excellent repeatability. The mechanism allows the probe's stylus to be deflected as it meets the surface of the part, whilst the spring ensures that the mechanism re-seats when the stylus is in free space.

The contact elements are made of tungsten carbide, a very hard substance, to ensure that the contact patches (where the material is elastically deformed under the force of the spring) are very small. An electrical circuit runs through the contacts, and it is the resistance through this circuit that is measured by the probe's electronics.

A trigger signal is generated on contact with the component surface and is used to stop the machine

A spring holds the stylus against the kinematic contacts and returns the probe to a seated position following contact between the stylus and the part

3 rods, each resting on two balls, providing 6 points of contact in a kinematic location

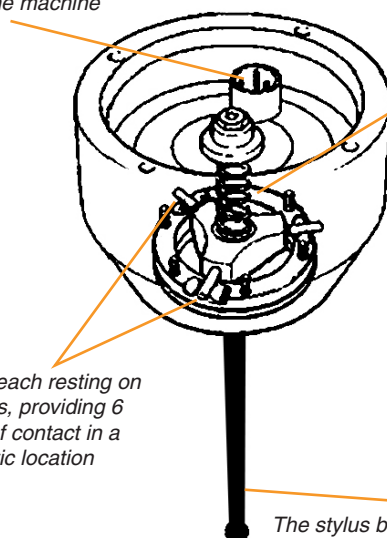

The stylus ball is uniquely located, returning to the same position within 1 μm (0.00004")

Figure 1: schematic of a kinematic resistive probe

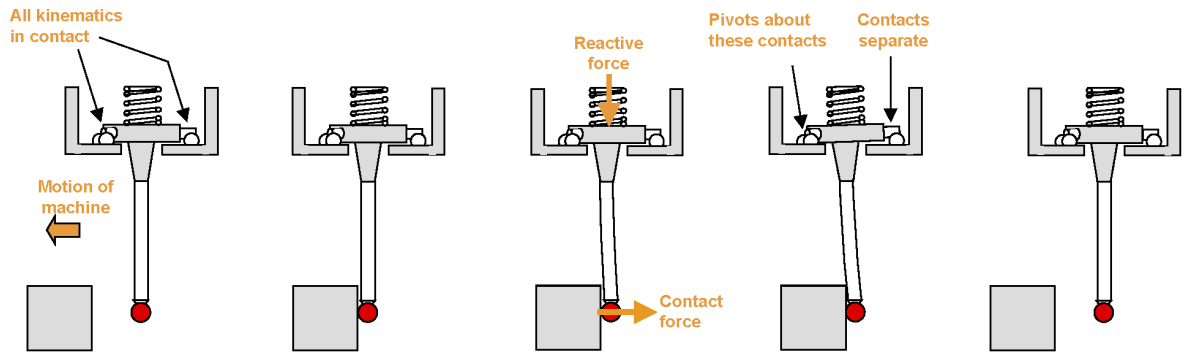

Figure 2: how a kinematic resistive probe generates a trigger

Figure 2 illustrates the mechanics of a trigger:

1. As the probe's stylus moves towards the component, the spring is holding all of the kinematic elements in contact, so that the stylus is in a known position relative to the quill / spindle.
2. The stylus meets the surface.
3. As the machine's motion continues to drive the stylus into contact with the component, forces start to build in the probe mechanism. The contact force at the stylus tip creates a moment in the probe mechanism about the set of contacts on the left hand side of the mechanism, which is balanced by a reactive moment generated by the spring, pivoting about the same set of contacts. As these forces build, the stylus undergoes bending (greatly exaggerated in the diagram for illustrative purposes).
4. Eventually, the increasing contact moment overcomes the reactive moment and the mechanism starts to pivot about the left-hand set of contacts. The contacts on the right move apart, breaking the electrical circuit in the probe. Before this occurs, a trigger is generated (see the section on electrical switching, below). The trigger signal is used to latch the machine's position at that moment, and to command the machine to slow down and back off the surface.
5. Once the machine backs off the surface, the probe re-seats into its repeatable rest position.

Electrical switching

An electrical circuit is made through the kinematic contacts. The ball plate is insulated from the tungsten carbide spheres, whilst the cylinders and the stylus carrier are also insulated from one another (see figure 3a). Wires in the ball plate carry the current between the contact sets.

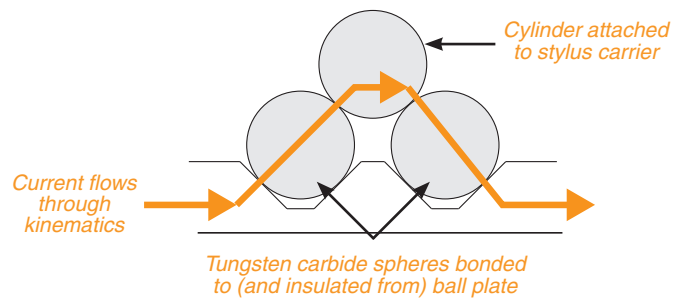

Under the load of the spring, the contact elements undergo elastic deformation (see figure 3b), creating small contact patches through which the current can flow. The resistance across each contact patch is inversely related to the area of the contact patch ($R = \rho/A$). As the force between the stylus and the component builds, the reactive moment that is generated in the probe mechanism causes the forces between some contact elements to increase, whilst the force between others will decrease. As the force between two contact elements reduces, the contact patch area gets smaller, thus increasing the resistance between those elements. With all six contact patches wired in series, the contacts with the lowest force between them greatly affects the overall resistance in the probe circuit.

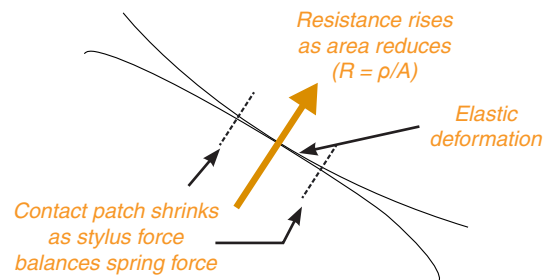

Figures 3a and 3b: electrical circuit through kinematics and close-up of the contact path between elements

When the resistance reaches a threshold, the probe's output is set to 'triggered' (see figure 4). Vitaly, the balls and rods are still in contact when the trigger occurs, so that the stylus is in a defined position, providing repeatable measurement.

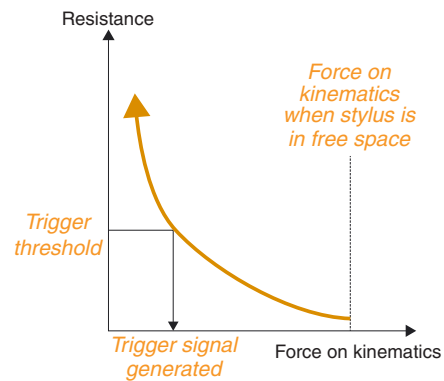

Figure 4: a trigger is generated when the probe circuit resistance breaches a threshold value

Factors in kinematic resistive probe performance

Pre-travel

When the stylus is in contact with the surface, a balance of forces is established. Before the trigger threshold is reached, these growing forces cause the stylus to bend. Since the machine is still moving, the amount of bending in the stylus that occurs before the probe triggers affects the latched position of the machine when the trigger is recorded.

This stylus bending prior to the trigger is known as **pre-travel**. Referring to figure 5, pre-travel depends on F_c and L , as well as the stiffness of the stylus, according to the formula:

Pre-travel = $F_c \cdot L^3 / 3EI$ (where E is the Young's modulus of the stylus stem material, and I is the moment of inertia).

Before the contact elements separate, the force balance is as follows:

$$F_c \cdot L = F_s \cdot R$$

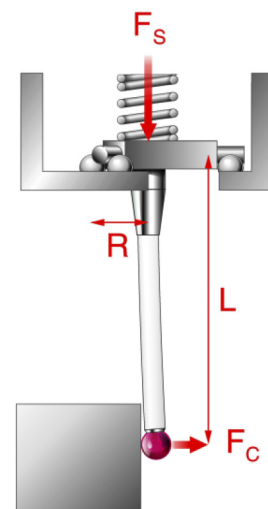

Figure 5: force balance in a touch-trigger probe

Pre-travel variation (lobing)

The contact sets in a kinematic resistive probe form a triangular arrangement. This means that the pivot distance R varies depending on the direction in which the contact force acts in relation to the probe mechanism. For an particular stylus (i.e. L is constant) the contact force F_c is proportional to R .

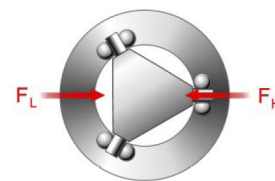

Figure 6: high and low force directions

Figure 6 shows how the contact force for a given stylus varies dependent on the direction of contact. In the low force direction (F_L), the pivot distance R is approximately half as long as in the high force direction (F_H). Figures 7a and 7b illustrate this in more detail. Since $R_1 > R_2$ therefore $F_{c1} > F_{c2}$. A larger force is needed to reach the trigger threshold in the high force direction, resulting in more pre-travel in that direction. Trigger force variation results in a phenomenon known as **pre-travel variation (PTV)** or lobing.

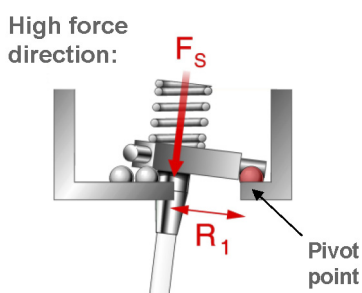

Figure 7a: pivot point is further from stylus centre-line in high force direction

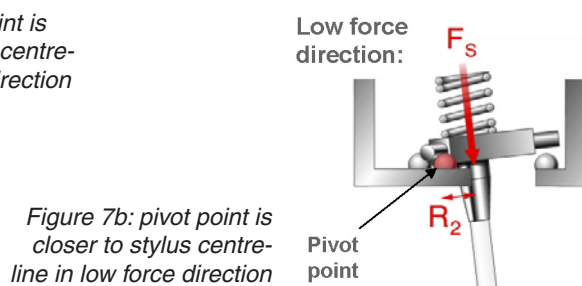

Figure 7b: pivot point is closer to stylus centre-line in low force direction

Figure 8 shows a typical XY pre-travel plot for a TP6 kinematic resistive CMM touch-trigger probe. The three high force directions can be seen as the peak points of this plot. The maximum variation in pre-travel in this case is around $3.3 \mu\text{m}$ (0.00013 in).

XYZ pre-travel variation

Pre-travel exists not only in the XY plane, but also in the Z direction. In this case, there is no mechanical advantage (lever action) over the probe spring, so the contact force is the same as the spring force (see figure 9); therefore the trigger force in this direction is much higher than that seen in the XY plane. However, since the stylus is in compression when triggering in this direction, its effective stiffness is much higher and the pre-travel in the Z direction is generally much smaller than in the XY plane.

Kinematic resistive probes exhibit 3-dimensional (XYZ) PTV, a combination of the XY and Z pre-travel effects. When measuring complex surfaces, this becomes an important characteristic.

Probe calibration

Pre-travel itself is not a form of error, since it can easily be compensated by probe calibration. A datum feature, of known size and position, is measured to establish the average pre-travel for the stylus concerned. Once this is complete, the key factor affecting measurement accuracy is the probe's **repeatability** (see next section).

However, there are some limitations. On complex parts, many probing directions may be needed. If the PTV value for the probe / stylus combination is sufficiently low, then its impact on the measurement accuracy may be acceptable. However, if this potential measurement error is unacceptably large, then it may be necessary to calibrate the probe for each direction in which it is to be used.

Repeatability

A probe's ability to trigger at the same point each time is known as its repeatability. This is a random error and kinematic resistive probes for machine tool applications typically repeat within $1.0 \mu\text{m}$ (0.00004 in) (2σ) at the stylus tip. Many CMM kinematic resistive probes can repeat within $0.35 \mu\text{m}$ (0.000014 in) (2σ). It is important to note that these are test rig values, and do not necessarily represent the *system* measurement repeatability. Any variability in the time taken to latch the machine position from when the probe issues a trigger signal will manifest itself as an increase in repeatability. Whilst CMM control designs have been optimised around the probe input, for CNC machine tools this is not always the case.

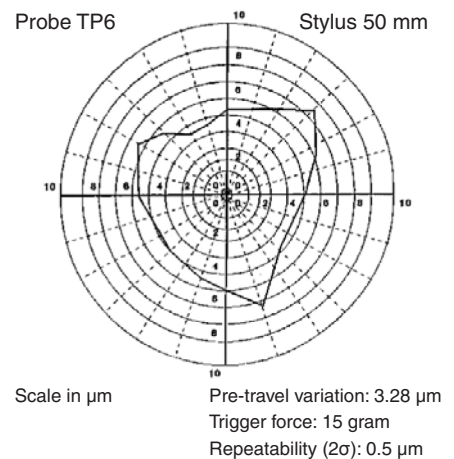

Figure 8: pre-travel variation plot for a TP6 CMM probe

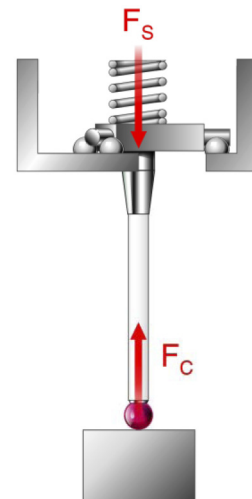

Figure 9: force balance in the Z direction

Other factors that can affect the measurement repeatability of machine tool probes include:

- **Sample frequency** of the probe signal by the machine controller - on CMMs this is normally a real time interrupt, whilst some CNC machine tools are fitted with high speed skip inputs to minimise the uncertainty of position at the point of trigger. However, some CNCs only sample the probe input every few milliseconds.
- **Transmission repeatability** - the variation in time taken to transmit a probe trigger signal to the controller. Renishaw optical and radio transmissions are designed to have a short and highly repeatable delay.

Hysteresis

The direction of the preceding probe trigger has a small effect on the point of the trigger - similar to backlash in a ball-screw mechanism. Hysteresis is maximised when a measurement follows a probing move in the opposite direction in the XY plane. This effect increases with stylus length and contact force. However, the kinematic mechanism minimises hysteresis so that it is typically only a small component of the probe's unidirectional repeatability.

Performance factors ranked in terms of importance

1. Repeatability

This is the key performance requirement of any trigger probe and represents the fundamental limit to system performance. Hysteresis contributes to repeatability.

2. Pre-travel variation

This factor can be removed through calibration, provided all the probing directions are known. Measurement accuracy will be reduced if a probe with a high PTV value is used in an unqualified direction. PTV increases rapidly with stylus length in kinematic resistive probes.

3. Hysteresis

A small factor for probes with kinematic mechanisms.

Strain gauge probe technology

A newer form of sensing technology has addressed the performance limitations of the kinematic resistive probe mechanism: silicon strain gauges. This has been made possible by modern compact electronics and solid state sensing, which Renishaw has engineered for probes as small as 13 mm (0.5 in) in diameter.

Although strain gauge probes still use a kinematic mechanism to retain the stylus, they do not use the resistance through the contact elements as the means to sense a trigger. Instead, a set of strain gauges is positioned on carefully designed webs in the probe structure above the kinematics (see figure 10). These gauges measure the contact force applied to the stylus and generate a trigger once the strain exceeds a threshold value. This provides a low trigger force, and, since the sensing is not dependent on the kinematics, a consistent trigger characteristic in all directions.

Measuring the contact force

Figure 11 shows a schematic of a strain gauge probe. At low contact forces, the kinematics remain seated and the force is transmitted through them to the probe structure. The strain gauges - three measuring gauges aligned to sense in the X, Y and Z axes - are mounted on thin webs. They detect forces in the structure and their outputs are summed together so that once a force threshold is breached in any direction, a trigger signal is generated. This threshold force is typically a few grams - much lower than the trigger force on an equivalent resistive sensor.

The strain gauges are highly sensitive to forces on the structure, and will detect vibrations on the machine whilst the stylus is not in contact with the surface of the part. Filtering circuitry inside the probe establishes whether the strains seen at the gauges are the result of a real and persistent deflection of the stylus. To achieve this, a short and highly repeatable delay is inserted into the detection circuit from the moment the force threshold is first breached, after which a persistent and increasing force must be seen before a trigger is issued at the end of the delay period.

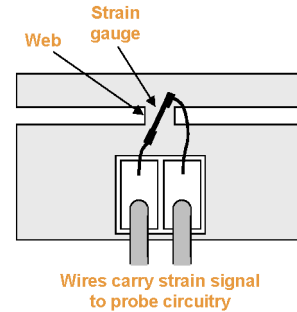

Figure 10: strain gauge mounted to web inside probe

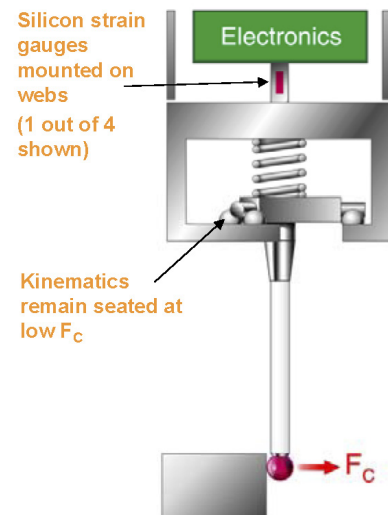

Figure 11: schematic of a strain gauge probe measuring the contact force

Rejecting false triggers and repeatable measurement

Figure 12a illustrates the case where there is significant noise on the strain gauge output value, caused by vibration on the machine. In this case, the threshold is breached by one particular vibration and the fixed delay timer starts. However, the force drops below the threshold and remains at a lower level so that, once the delay period has expired, the electronics can identify that a real trigger has not occurred, so no trigger signal is issued.

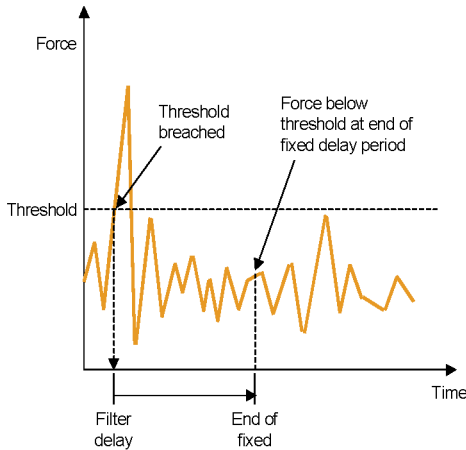

Figure 12a: a random vibration breaches strain gauge force threshold - no trigger issued

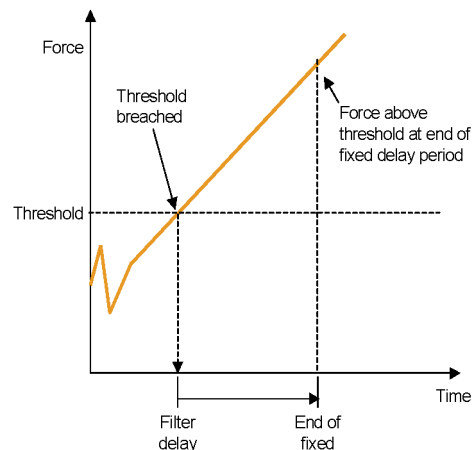

Figure 12b: a persistent force due to a probe trigger breaches strain gauge force - trigger signal is issued at the end of the delay period

Meanwhile, figure 12b shows the case where the stylus meets the surface. Once the stylus strikes the surface, random vibrations are quickly damped out as the strain gauges measure the contact force. The force seen at the gauges rises persistently, so that once the timer starts, the force never falls below the threshold again. At the end of the repeatable delay period, a trigger signal is issued.

This repeatable delay is easily removed with probe calibration. The net effect is an apparent reduction in the radius of the stylus ball, equal to the distance moved by the machine during the fixed delay period. Provided the machine moves at a constant speed during this period, measurement repeatability is unaffected. This means that the probe must be calibrated at the same programmed feedrate at which measurements will occur, making strain gauge probes suitable only for automated CMMs and CNC machine tools. A further consideration is the programmed target position - the point beyond the expected position of the surface towards which the machine is programmed to move during the probing cycle. Manufacturing engineers must ensure that as the machine moves towards this target position, it does not start to decelerate before the stylus meets the surface. The over-travel distance must therefore take account of both the likely variation in surface position, as well as the deceleration profile of the machine.

Performance benefits

Figure 14 shows a typical pre-travel variation plot for an OMP400 touch-trigger probe where 12 points are taken at 30° increments around a circle. The chart shows a typical PTV plot for an OMP400 touch probe, showing a low and almost uniform pre-travel in all directions. Using a 50 mm stylus, the PTV value in the XY plane is just 0.34 μm (0.000013 in), or roughly 90% less than the PTV value for a similarly sized kinematic touch probe. The OMP400 touch probe typically exhibits XYZ PTV values of less than 1 μm.

These performance benefits manifest themselves in more accurate measurement, especially on complex parts where many sensing directions are used. The low PTV value means that a simple probe calibration routine can be used.

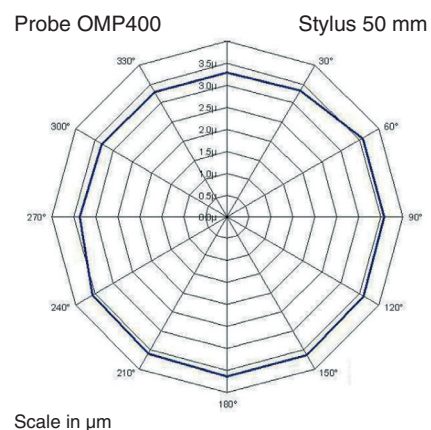

Figure 14: pre-travel variation plot for an OMP400 touch-trigger probe

Life and reliability benefits

Another benefit of strain gauge technology is the longer operational life that can be achieved - typically more than 10 times longer than resistive probes. Using solid state strain gauges means that there is almost no degradation of the kinematic contacts, which are used solely for their mechanical re-seat properties. In contrast, resistive probes start to exhibit increasing re-seat failures over time. The resistance through the contacts eventually fails to fall below the trigger threshold due to microdegradation of the surfaces. Furthermore, unlike resistive probes, strain gauge sensors do not suffer from vibration-induced false triggers. These characteristics make them suitable for intensive touch-trigger probing applications.

Flexibility

In kinematic resistive probes, the pre-travel variation increases rapidly with stylus length (PTV is proportional to the cube of the stylus length). This means that measurement performance requirements limit the length of stylus that can be used. Whilst this is overcome in many cases by the use of an extension bar, an indexing head and / or the small size of the probe itself, there are some inspection applications that demand a very long stylus. Strain gauge sensors, with their lower and more consistent trigger forces, can provide superior measurement performance and support much longer styli. In the case of the RMP600 spindle probe for machine tools (see figure 15), styli up to 300 mm long can be used, with only a small decrease in measurement performance.

	Stylus length	
	50 mm	100 mm
Repeatability Max. 2σ in any direction of 12	0.25 μm	0.35 μm
2D (XY) lobing Max. deviation from a ring gauge	$\pm 0.25 \mu\text{m}$	$\pm 0.25 \mu\text{m}$
3D (XYZ) lobing Max. deviation from a known sphere	$\pm 1.00 \mu\text{m}$	$\pm 1.75 \mu\text{m}$

Some measurement applications demand very small styli to access the features to be measured. The low probing force of strain gauge sensors means that less rigid styli can still be used.

Summary

Touch-trigger probes - kinematic resistive and strain gauge sensors - are the most widely used forms of contact sensor used on CMMs and CNC machine tools. Despite the recent increase in the use of scanning probes on CMMs, touch-trigger probes continue to play an important role in quality assurance and process control in many fields of manufacturing. Their design has evolved to meet the needs of a wide range of measurement tasks, with innovative sensing technology providing improved performance, a longer operating life and increased flexibility.

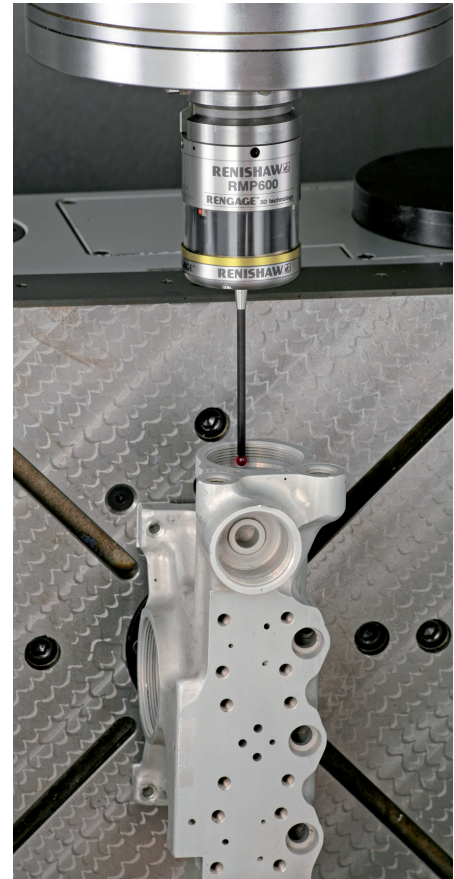

Figure 15: RMP600 strain gauge spindle probe

This page is intentionally left blank

Renishaw plc
New Mills, Wotton-under-Edge,
Gloucestershire GL12 8JR
United Kingdom

T +44 (0) 1453 524524
F +44 (0) 1453 524901
E uk@renishaw.com
www.renishaw.com

RENISHAW 
apply innovation™

About Renishaw

Renishaw is an established world leader in engineering technologies, with a strong history of innovation in product development and manufacturing. Since its formation in 1973, the company has supplied leading-edge products that increase process productivity, improve product quality and deliver cost-effective automation solutions.

A worldwide network of subsidiary companies and distributors provides exceptional service and support for its customers.

Products include:

- **Dental CAD/CAM scanning and milling systems.**
- **Encoder systems for high accuracy linear, angle and rotary position feedback.**
- **Laser and ballbar systems for performance measurement and calibration of machines.**
- **Medical devices for neurosurgical applications.**
- **Probe systems and software for job set-up, tool setting and inspection on CNC machine tools.**
- **Raman spectroscopy systems for non-destructive material analysis.**
- **Sensor systems and software for measurement on CMMs (co-ordinate measuring machines).**
- **Styli for CMM and machine tool probe applications.**

Renishaw worldwide

Australia

T +61 3 9521 0922
E australia@renishaw.com

Austria

T +43 2236 379790
E austria@renishaw.com

Brazil

T +55 11 4195 2866
E brazil@renishaw.com

Canada

T +1 905 828 0104
E canada@renishaw.com

The People's Republic of China

T +86 21 6180 6416
E china@renishaw.com

Czech Republic

T +420 548 216 553
E czech@renishaw.com

France

T +33 1 64 61 84 84
E france@renishaw.com

Germany

T +49 7127 9810
E germany@renishaw.com

Hong Kong

T +852 2753 0638
E hongkong@renishaw.com

Hungary

T +36 23 502 183
E hungary@renishaw.com

India

T +91 80 6623 6000
E india@renishaw.com

India

T +91 80 6623 6000
E india@renishaw.com

Indonesia

T +62 21 2550 2467
E indonesia@renishaw.com

Italy

T +39 011 966 10 52
E italy@renishaw.com

Japan

T +81 3 5366 5316
E japan@renishaw.com

Malaysia

T +60 3 5631 4420
E malaysia@renishaw.com

The Netherlands

T +31 76 543 11 00
E benelux@renishaw.com

Poland

T +48 22 577 11 80
E poland@renishaw.com

Russia

T +7 495 231 16 77
E russia@renishaw.com

Singapore

T +65 6897 5466
E singapore@renishaw.com

Slovenia

T +386 1 527 2100
E mail@rls.si

South Korea

T +82 2 2108 2830
E southkorea@renishaw.com

Spain

T +34 93 663 34 20
E spain@renishaw.com

Sweden

T +46 8 584 90 880
E sweden@renishaw.com

Switzerland

T +41 55 415 50 60
E switzerland@renishaw.com

Taiwan

T +886 4 2473 3177
E taiwan@renishaw.com

Thailand

T +66 2 746 9811
E thailand@renishaw.com

Turkey

T +90 216 380 92 40
E turkiye@renishaw.com

UK (Head Office)

T +44 1453 524524
E uk@renishaw.com

USA

T +1 847 286 9953
E usa@renishaw.com

For all other countries

T +44 1453 524524
E international@renishaw.com

RENISHAW HAS MADE CONSIDERABLE EFFORTS TO ENSURE THE CONTENT OF THIS DOCUMENT IS CORRECT AT THE DATE OF PUBLICATION BUT MAKES NO WARRANTIES OR REPRESENTATIONS REGARDING THE CONTENT. RENISHAW EXCLUDES LIABILITY, HOWSOEVER ARISING, FOR ANY INACCURACIES IN THIS DOCUMENT.

©2010-2011 Renishaw plc. All rights reserved.

Renishaw reserves the right to change specifications without notice

RENISHAW® and the probe emblem used in the RENISHAW logo are registered trademarks of Renishaw plc in the UK and other countries. apply innovation, Productive Process Pyramid, Productive Process Patterns, Productivity+, AxiSet, Rengage, Trigger Logic, ToolWise, Sprint, MicroHole, PassiveSeal, SwarfStop, Equator and the versatile gauge are trademarks of Renishaw plc.

All other brand names and product names used in this document are trade names, service marks, trademarks or registered trademarks of their respective owners.



H - 5650 - 2014 - 01

Issued 0411 Part no. H-5650-2014-01-C